

Electric Pressure Regulator (EPR)

AST's Electric Pressure Regulator (EPR) reduces variable high storage pressure of inert gases to a stable low-pressure. The high pressure at unit inlet is measured and reduced by controlled expansion in two steps to intermediate and final outlet pressures. The pressure control is achieved through on-off- switching of high-pressure miniature valves and accurate reading of the downstream pressure.

The unit can be controlled to outlet pressures within the measurement-range of the integrated low-pressure sensor. Depending on the control electronics design, the setpoint

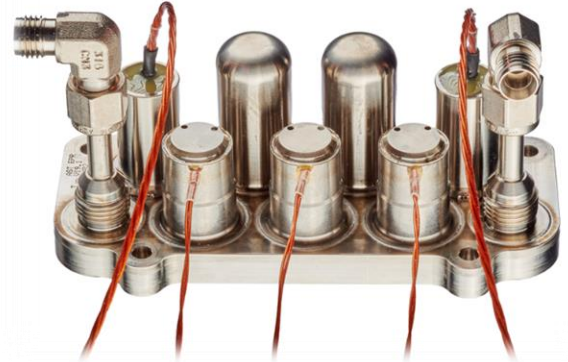

can be varied (e.g. in orbit) to adapt to different mission phases. The high-pressure sensor reading can be used to perform propellant gauging.

Up to three high-pressure valves can be integrated in the EPR which form series redundant barriers to the high-pressure section. Only stainless steel and FKM materials are in contact with the gas which provide good compatibility and allow a very wide range of applications.

The stainless-steel EPR is an all-welded design which provides robustness against rupture and propellant loss. All high-pressure joints are made by electron-beam welding and each unit is proof-pressure and leakage tested before shipment. Inlet and outlet filters protect the unit during handling and integration.

Customers can request the EPR being configured to meet high or low massflow requirements. The outlet pressure ripple performance can be matched to the needs through flow restricting elements and considering the downstream ullage.

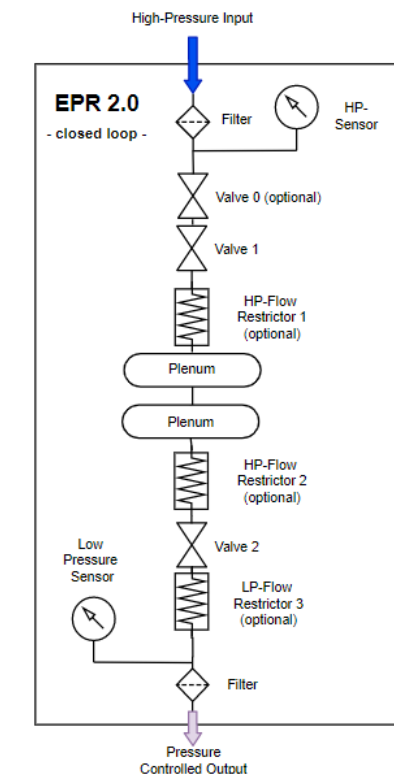

Through its integrated functions, the EPR can simplify the fluidic architecture of a propulsion subsystem. The typical use-case is for a distributed thruster configuration, e.g. Cold-Gas or EP-thruster with individual Flow Control Units (FCU).

All components of the EPR design are fully qualified and have flight-heritage. An extended, modular design concept of the EPR is currently in development.

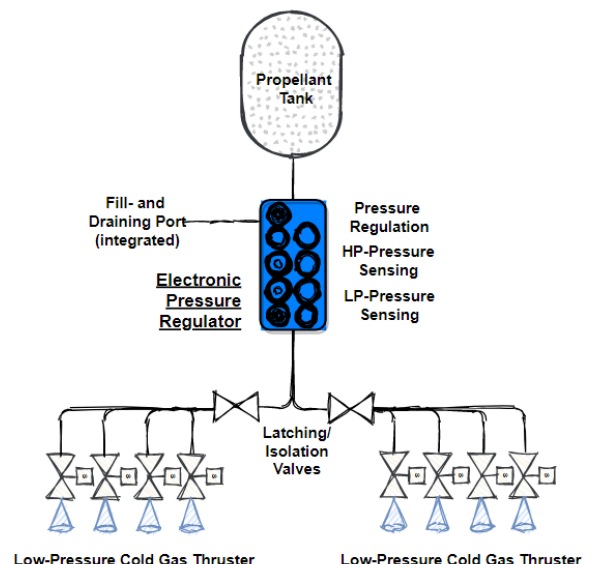

EPR - Characteristics

<i>Parameter</i>	<i>Value</i>	<i>Remark</i>
<i>Operating Media</i>	<i>He, N2, Xe, Kr</i>	<i>Xe, N2 with flight heritage</i>
<i>Inlet Pressure MEOP</i>	<i>300 bar</i>	<i>Xe operation up to 186 bar qualified N2 operation up to 300 bar</i>
<i>Inlet Pressure EOL</i>	<i>2 bar</i>	<i>depending on required massflow</i>
<i>Proof Pressure</i>	<i>1.5 x MEOP</i>	<i>design value > 450 bar</i>
<i>Low Pressure Line MEOP</i>	<i>1 or 4 bar</i>	<i>depending on LP sensor selection</i>
<i>Low Pressure Lines Proof Pressure</i>	<i>7 bar</i>	<i>limited by LP sensor</i>
<i>Burst Pressure</i>	<i>>2.5 x MEOP</i>	<i>design value > 750 bar</i>
<i>Massflow Rates – fine mode</i>	<i>> 10 mg/s</i>	<i>selectable by design; depends on gas</i>
<i>Massflow Rates – coarse mode</i>	<i>> 250 mg/s</i>	<i>selectable by design; depends on gas</i>
<i>Outlet Pressure ripple</i>	<i>< 20 mbar</i>	<i>in fine-mode; depending on downstream ullage</i>
<i>Internal Leakage</i>	<i>< 1*10⁻⁵ sccs GHe</i>	<i>verified during acceptance tests</i>
<i>External Leakage</i>	<i>< 1*10⁻⁸ sccs GHe</i>	<i>verified during acceptance tests</i>
<i>Thermal Range non-op</i>	<i>-20°C to +80°C</i>	<i>incl. qualification margin</i>
<i>Thermal Range op</i>	<i>+25°C to +65°C</i>	<i>full performance, depending on gas</i>
<i>Thermal Range op (cold start)</i>	<i>-10°C to +65°C</i>	<i>limited performance (heater recommended)</i>
<i>Fluid Filtration Rate</i>	<i>11µm</i>	<i>5µm mesh at inlet and outlet</i>
<i>Mass</i>	<i>< 900 g</i>	<i>w/o harness, varying with configuration</i>
<i>Average Power Consumption</i>	<i><10 W</i>	<i>depending on valve actuation frequency</i>
<i>Valve Operating Voltage</i>	<i>24V to 32V</i>	<i>min pull-in voltage required for motorization margin; 50% hold-voltage</i>
<i>Pressure Sensor Excitation Volage</i>	<i>10V</i>	<i>in sensor voltage excitation mode</i>
<i>Vibration Qualification Levels</i>	<i>>20 gRMS</i>	<i>all 3 axis</i>
<i>Radiation Tolerance</i>	<i>30 Mrad</i>	<i>Total Ionizing Dose (TID)</i>

EPR- Customization Options

AST's EPR design allows customer/mission-specific configuration based on qualified building-block components. The complete fluidic management can be integrated in on one compact assembly. Examples of past configurations are shown below.

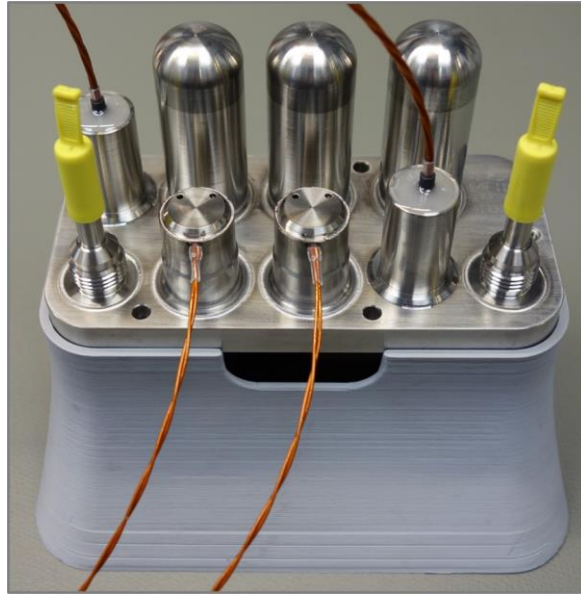

Figure 1: example of an EPR with two high-pressure valves for use in high-flow applications

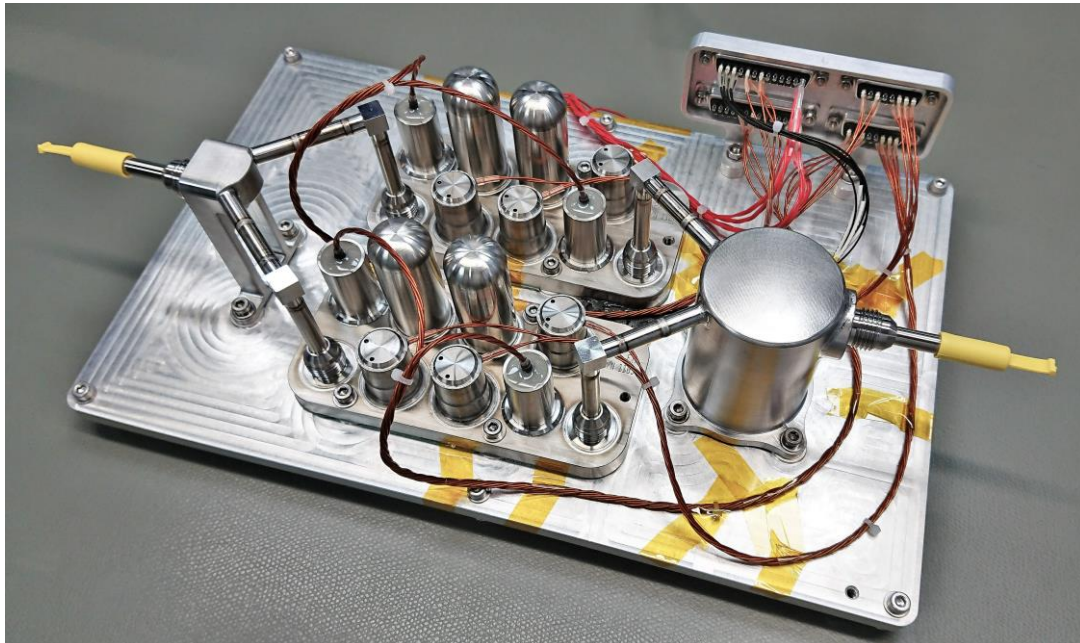

Figure 2: example of a redundant EPR configuration with three high-pressure valves for high-throughput and low massflow-ripple application

The EPR characteristics are subject to changes. Please contact AST for details and requests on further options.